

PRODUCT NO.
92194

PRODUCT NO. *92194-XXXXX	STAND OFF DIM "M"(mm)	UPPER DECK			LOWER DECK			DIM "P" (mm)	HDR COLOR	SHEET NO.	MOUNTING STYLE TO PCB & DIRECTION OF PUSH ROD
		(MECH+HDR) 92711-XXXXX	(MECH) 92192-XXXX	(HDR) 92140-XXX	(MECH+HDR) 92193-XXXXX	(MECH) 92192-XXXX	(HDR) 92140-XXX				
000CA	0	000CA	00CA	005	100CA	00CA	000	2.8	BLACK	NO.2	
000CALF	0	000CALF	00CA	005LF	100CALF	10CA	000LF	2.8	BLACK		
020CA	2	020CA	00CA	045	120CA	12CA	040	2.5	BLACK		
020CALF	2	020CALF	00CA	045LF	120CALF	12CA	040LF	2.5	BLACK	NO.3	
100CA	0	100CA	10CA	005	000CA	00CA	000	2.8	BLACK		
100CALF	0	100CALF	10CA	005LF	000CALF	00CA	000LF	2.8	BLACK		
120CA	2	120CA	10CA	045	020CA	02CA	040	2.5	BLACK	NO.4	
120CALF	2	120CALF	10CA	045LF	020CALF	02CA	040LF	2.5	BLACK		
200CA	0	000CA	00CA	005	000CA	00CA	000	2.8	BLACK		
200CALF	0	000CALF	00CA	005LF	000CALF	00CA	000LF	2.8	BLACK	NO.5	
200FA	0	000FA	00FA	005	000FA	00FA	000	2.8	BLACK		
200FALF	0	000FALF	00FA	005LF	000FALF	00FA	000LF	2.8	BLACK		
220CA	2	020CA	00CA	045	020CA	02CA	040	2.5	BLACK	NO.6	
220CALF	2	020CALF	00CA	045LF	020CALF	02CA	040LF	2.5	BLACK		
300CA	0	100CA	10CA	005	100CA	10CA	000	2.8	BLACK		
300CALF	0	100CALF	10CA	005LF	100CALF	10CA	000LF	2.8	BLACK	NO.7	
320CA	2	120CA	10CA	045	120CA	12CA	040	2.5	BLACK		
320CALF	2	120CALF	10CA	045LF	120CALF	12CA	040LF	2.5	BLACK		
320FA	2	120FA	10FA	045	120FA	12FA	040	2.5	BLACK	NO.8	
320FALF	2	120FALF	10FA	045LF	120FALF	12FA	040LF	2.5	BLACK		
320GALF	2	120GALF	10CA	045LF	120GALF	12GALF	040LF	2.5	BLACK		
500CA	0	600CA	00CA	505	500CA	10CA	500	2.8	NATURAL	NO.9	
500CALF	0	600CALF	00CA	505LF	500CALF	10CA	500LF	2.8	NATURAL		
500FA	0	600FA	00FA	505	500FA	10FA	500	2.8	NATURAL		
500FALF	0	600FALF	00FA	505LF	500FALF	10FA	500LF	2.8	NATURAL	NO.9	
520CA	2	620CA	00CA	545	520CA	12CA	540	2.5	NATURAL		
520CALF	2	620CALF	00CA	545LF	520CALF	12CA	540LF	2.5	NATURAL		
600CA	0	500CA	10CA	505	600CA	00CA	500	2.8	NATURAL	NO.9	
600CALF	0	500CALF	10CA	505LF	600CALF	00CA	500LF	2.8	NATURAL		
620CA	2	520CA	10CA	545	620CA	02CA	540	2.5	NATURAL		
620CALF	2	520CALF	10CA	545LF	620CALF	02CA	540LF	2.5	NATURAL	NO.9	
700CA	0	500CA	10CA	505	500CA	10CA	500	2.8	NATURAL		
700CALF	0	500CALF	10CA	505LF	500CALF	10CA	500LF	2.8	NATURAL		
720CA	2	520CA	10CA	545	520CA	12CA	540	2.5	NATURAL	NO.9	
720CALF	2	520CALF	10CA	545LF	520CALF	12CA	540LF	2.5	NATURAL		
800CA	0	600CA	00CA	505	600CA	00CA	500	2.8	NATURAL		
800CALF	0	600CALF	00CA	505LF	600CALF	00CA	500LF	2.8	NATURAL	NO.9	
820CA	2	620CA	00CA	545	620CA	02CA	540	2.5	NATURAL		
820CALF	2	620CALF	00CA	545LF	620CALF	02CA	540LF	2.5	NATURAL		

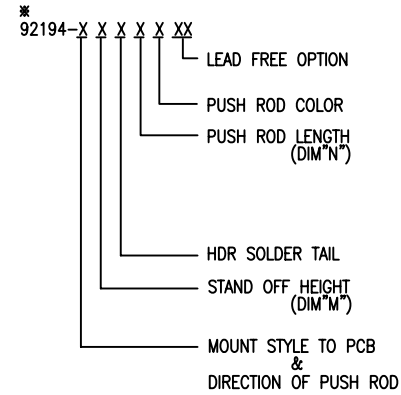

NONE : NO
LF : YES (SEE NOTE5)

A : BLACK
C : 13mm
F : 21mm
G : 27mm

0 : R/A

0 : 0mm(NONE)
2 : 2mm

- 0 : TOP MOUNT & RIGHT-LEFT PUSH ROD
- 1 : TOP MOUNT & LEFT-RIGHT PUSH ROD
- 2 : TOP MOUNT & RIGHT-RIGHT PUSH ROD
- 3 : TOP MOUNT & LEFT-LEFT PUSH ROD
- 5 : BOTTOM MOUNT & RIGHT-LEFT PUSH ROD
- 6 : BOTTOM MOUNT & LEFT-RIGHT PUSH ROD
- 7 : BOTTOM MOUNT & RIGHT-RIGHT PUSH ROD
- 8 : BOTTOM MOUNT & LEFT-LEFT PUSH ROD

NOTE
1. THIS PRODUCT MEETS EUROPEAN UNION DIRECTIVES AND OTHER COUNTRY REGULATIONS AS DESCRIBED IN GS-22-008.
2. PRODUCT SPEC: 110-263

mat'l. code		surface ISO1302		tolerance ISO1302 ISO1101		projection		product family PCMCIA	
ltr		ecn no		dr		date		title	
H		ELX-N-007950		ZK		11/01/11		68P DOUBLE EJECTOR HEADER ASSY FOR TYPE I/II/III	
J		ELX-N-011430		ZK		04/23/12		scale 2:1	
K		ELX-N-20919		J.H		05/27/15		sheet. 1 of 9	
dr		M.HASEGAWO		06/17/05		engr		92194	
M.H		08/16/04		chr		M.HASEGAWO		A4	
M.H		6/17/05		app		M.HASEGAWO		Product Customer Drawing	
sheet		revision		k		index		sheet 1-9	

PART NO.	
92194-000CA	92194-000CALF
92194-020CA	92194-020CALF

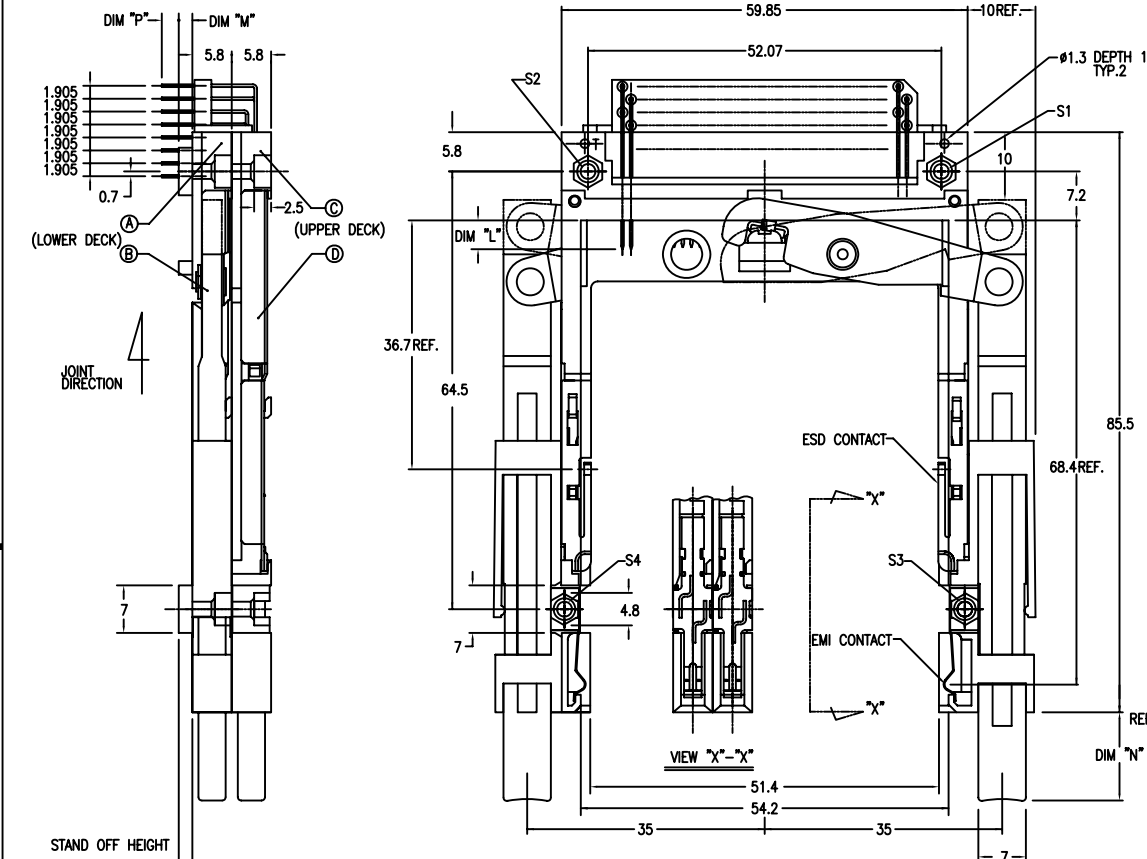

NOTE

- EJECT FORCE 3.5kg MAX.
- ASSY PROCESS
 - TO MOUNT PART ④, ⑤ ON PWB WITH SCREW (S1,S2) AND SOLDER.
 - TO JOINT PART ④, ⑤ INTO PART ① THEN FIX PART ④, ⑤ WITH 2 SCREWS (S3,S4).
- EJECT TRAVEL 8.0mm

④ MATERIAL

4.1 PART ④, ⑤ (HEADER ASSY)
 PLASTIC : HIGH TEMPERATURE THERMOPLASTIC UL94V-0 BLACK
 PIN : COPPER ALLOY

4.2 PART ④, ⑤ (EJECT MECHANISM ASSY)
 PLASTIC : HIGH TEMPERATURE THERMOPLASTIC UL94V-0 BLACK
 PLATE : STAINLESS
 EMI CONTACT : COPPER ALLOY

⑤ -1 FINISH (PIN)

UNDER PLATING : 0.5 μm MIN. Ni
 CONTACT AREA : 0.076 μm MIN. GOLD
 SOLDER TAIL : 2.5 μm MIN. Sn-Pb.

⑤ -2 FINISH (PIN) (FOR -****#F)

UNDER PLATING : 0.5 μm MIN. Ni
 CONTACT AREA : 0.076 μm MIN. GOLD
 SOLDER TAIL : 2.5 μm MIN. Sn.

6.	DIM "L"	4.25±0.1	3.5±0.1	5.0±0.1
	PIN NUMBER	OTHERS	36.67	35.66

7. GENERAL TOLERANCE : ±0.3

8. SEE SHEET 1 REGARDING COMPONENTS

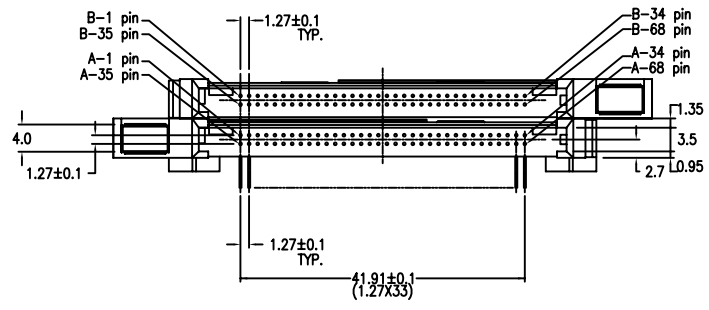
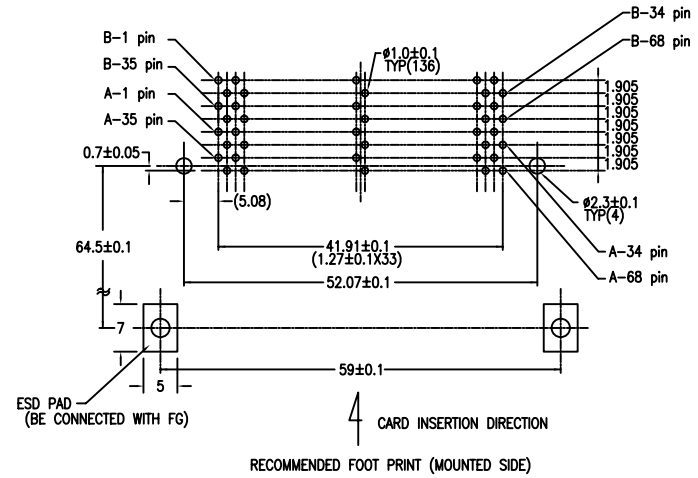

mat'l. code	surface	tolerance	projection	product family
	ISO1302	ISO1302 ISO1101		PCMCIA
ltr	ecn no	dr	date	title
K				68P DOUBLE EJECTOR HEADER ASSY FOR TYPE I/II/III
				dwg no
				92194
				sheet. 2 of 9
				size
				A4
				type
				Product Customer Drawing
sheet	revision			
index	sheet			

PRODUCT NO.	
92194-100CA	92194-100CALF
92194-120CA	92194-120CALF

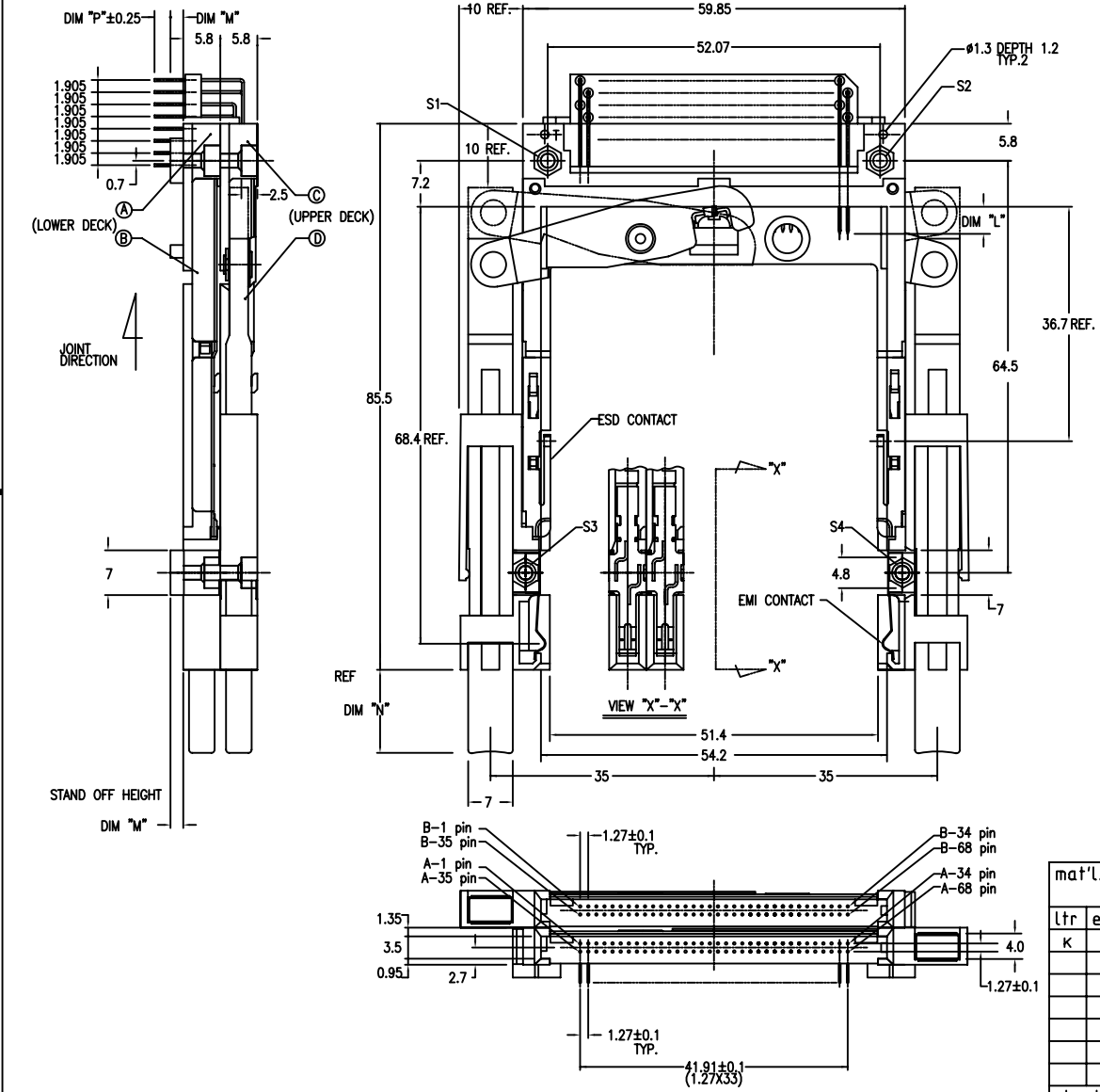

- NOTE
- EJECT FORCE 3.5kg MAX.
 - ASSY PROCESS
 - TO MOUNT PART ④, ⑤ ON PWB WITH SCREW (S1,S2) AND SOLDER.
 - TO JOINT PART ④, ⑤ INTO PART ③ THEN FIX PART ④, ⑤ WITH 2 SCREWS (S3,S4).
 - EJECT TRAVEL 8.0mm
 - MATERIAL
 - PART ④, ⑤ (HEADER ASSY)
 PLASTIC : HIGH TEMPERATURE THERMOPLASTIC UL94V-0 BLACK
 PIN : COPPER ALLOY
 - PART ③, ⑥ (EJECT MECHANISM ASSY)
 PLASTIC : HIGH TEMPERATURE THERMOPLASTIC UL94V-0 BLACK
 PLATE : STAINLESS
 EMI CONTACT : COPPER ALLOY
 - FINISH (PIN)
 - FINISH (PIN)
 UNDER PLATING : 0.5 μm MIN. Ni
 CONTACT AREA : 0.076 μm MIN. GOLD
 SOLDER TAIL : 2.5 μm MIN. Sn-Pb.
 - FINISH (PIN) (FOR *****LF)
 UNDER PLATING : 0.5 μm MIN. Ni
 CONTACT AREA : 0.076 μm MIN. GOLD
 SOLDER TAIL : 2.5 μm MIN. Sn.
- | | | | |
|------------|----------|---------|---------|
| DIM "L" | 4.25±0.1 | 3.5±0.1 | 5.0±0.1 |
| PIN NUMBER | 1734 | 36.67 | 352188 |
6. GENERAL TOLERANCE : ±0.3
8. SEE SHEET 1 REGARDING COMPONENTS

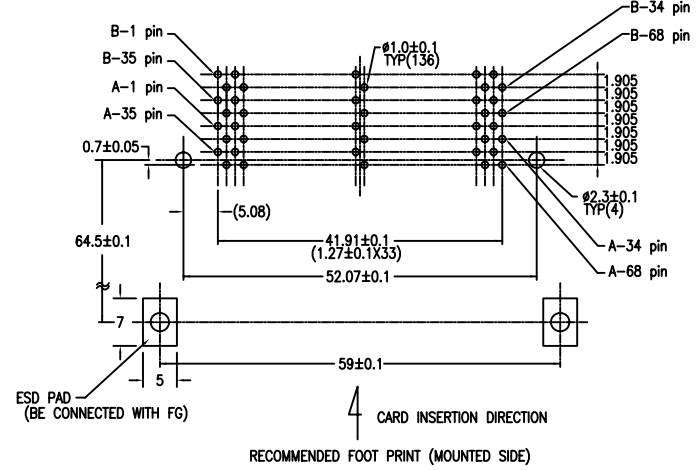

mat'l. code	surface	tolerance	projection	product family
	ISO1302	ISO1302 ISO1101		PCMCIA
ltr	ecn no	dr	date	title
K				68P DOUBLE EJECTOR HEADER ASSY FOR TYPE I/II/III
	angles			dwg no
	0°±x'	0.X±0.3	0.XX±0.13	sheet. 3 of 9
	dr	M.HASEGAWO	06/17/05	size
	engr	M.HASEGAWO	06/17/05	A4
	chr	M.HASEGAWO	06/20/05	
	appd	M.HASEGAWO	06/20/05	
sheet	revision			type
index	sheet			Product Customer Drawing

PART NO.	
92194-200CA	92194-200CALF
92194-200FA	92194-200FALF
92194-220CA	92194-220CALF

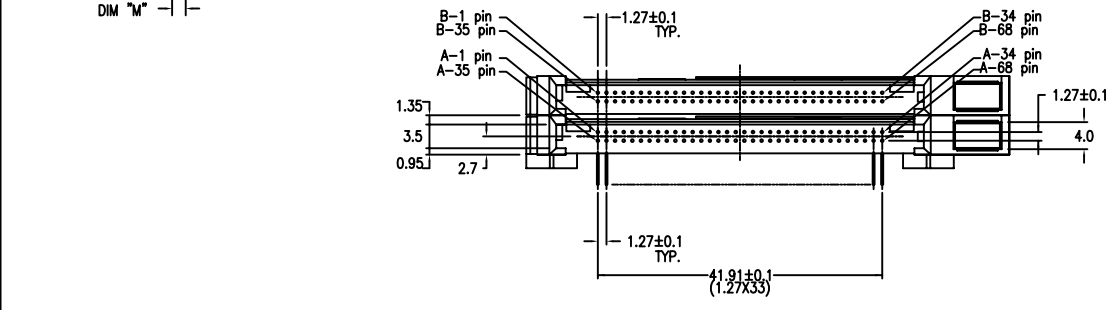
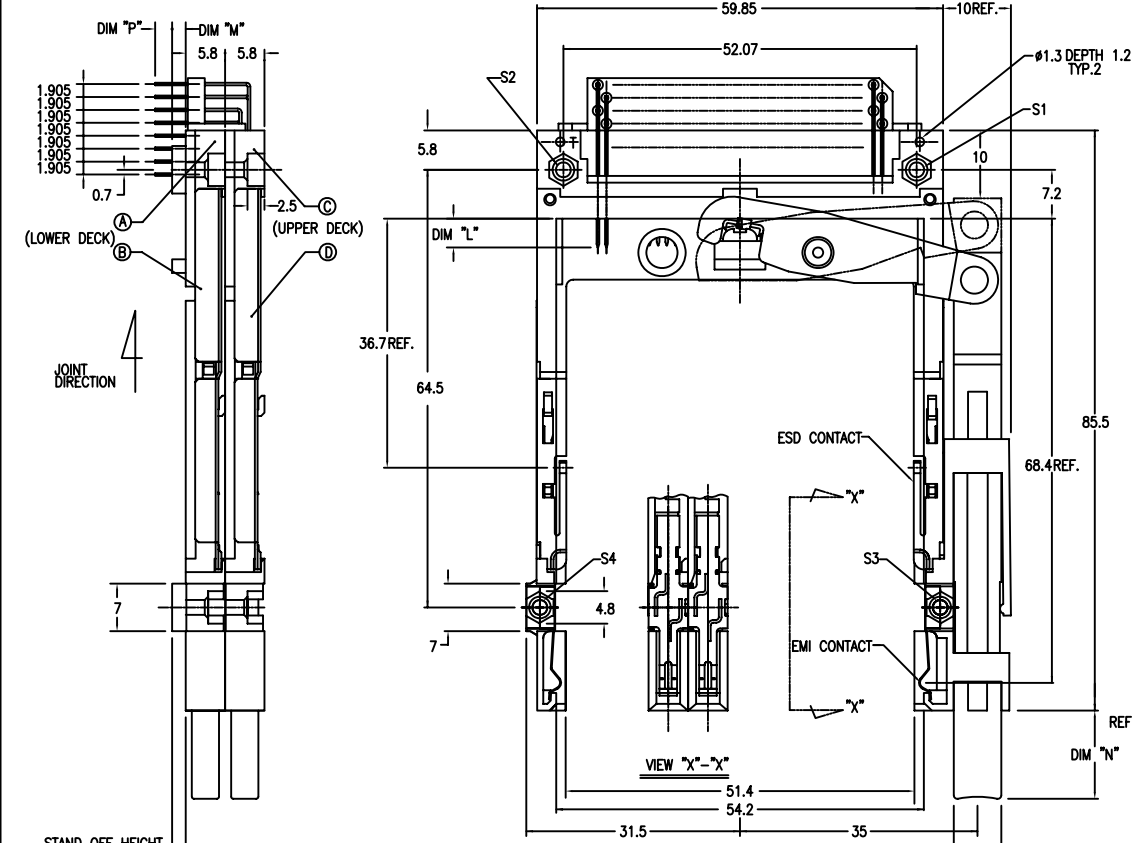

- NOTE
- EJECT FORCE 3.5kg MAX.
 - ASSY PROCESS
 - TO MOUNT PART ④, ⑤ ON PWB WITH SCREW (S1,S2) AND SOLDER.
 - TO JOINT PART ③, ① INTO PART ④, ② THEN FIX PART ③, ① WITH 2 SCREWS (S3,S4).
 - EJECT TRAVEL 8.0mm

④ MATERIAL
 4.1 PART ④, ⑤ (HEADER ASSY)
 PLASTIC : HIGH TEMPERATURE THERMOPLASTIC UL94V-0 BLACK
 PIN : COPPER ALLOY

4.2 PART ③, ① (EJECT MECHANISM ASSY)
 PLASTIC : HIGH TEMPERATURE THERMOPLASTIC UL94V-0 BLACK
 PLATE : STAINLESS
 EMI CONTACT : COPPER ALLOY

⑤ -1 FINISH (PIN)
 UNDER PLATING : 0.5 μm MIN. Ni
 CONTACT AREA : 0.076 μm MIN. GOLD
 SOLDER TAIL : 2.5 μm MIN. Sn-Pb.

⑤ -2 FINISH (PIN) (FOR -****LF)
 UNDER PLATING : 0.5 μm MIN. Ni
 CONTACT AREA : 0.076 μm MIN. GOLD
 SOLDER TAIL : 2.5 μm MIN. Sn.

6.

DIM "L"	4.25±0.1	3.5±0.1	5.0±0.1
PIN NUMBER	OTHERS	36.67	117.34 36.51.68

7. GENERAL TOLERANCE : ±0.3

8. SEE SHEET 1 REGARDING COMPONENTS

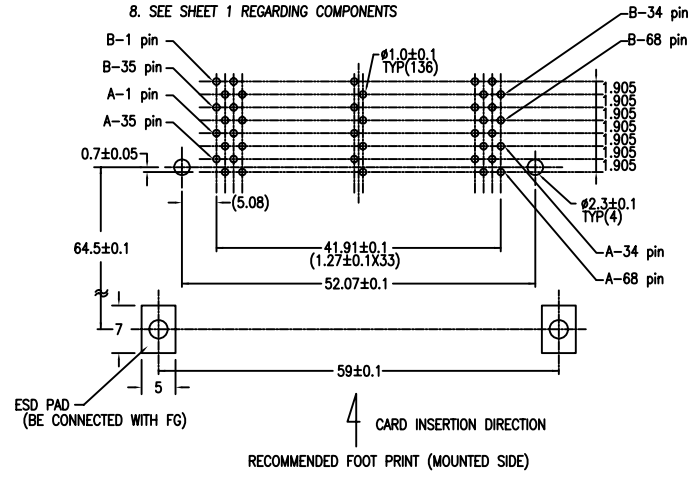

mat'l. code		surface		tolerance		projection		product family	
		ISO1302		ISO1302 ISO1101				PCMCIA	
ltr		ecn no		dr		date		title	
K								68P DOUBLE EJECTOR HEADER ASSY FOR TYPE I/II/III	
								dwg no	
								sheet. 4 of 9	
								size	
								A4	
								type	
								Product Customer Drawing	
sheet index		revision sheet							

PRODUCT NO.	
92194-300CA	92194-300CALF
92194-320CA	92194-320CALF
92194-320FA	92194-320FALF
92194-320GALF	

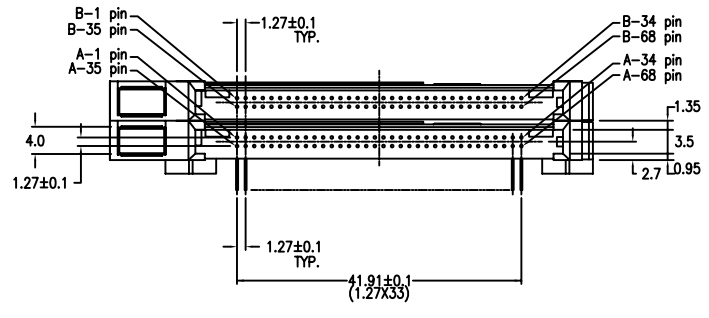
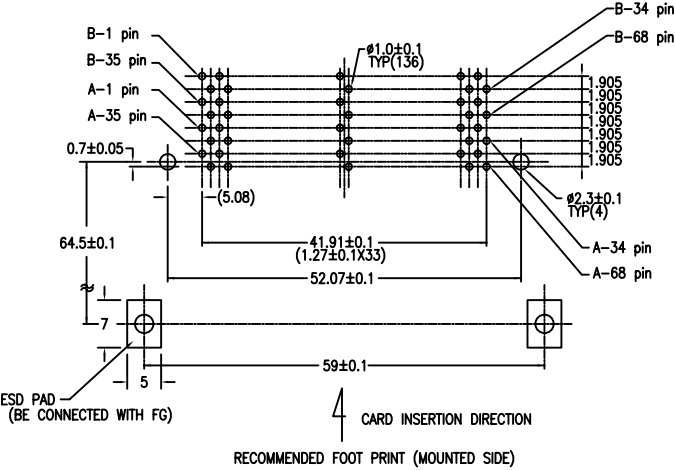
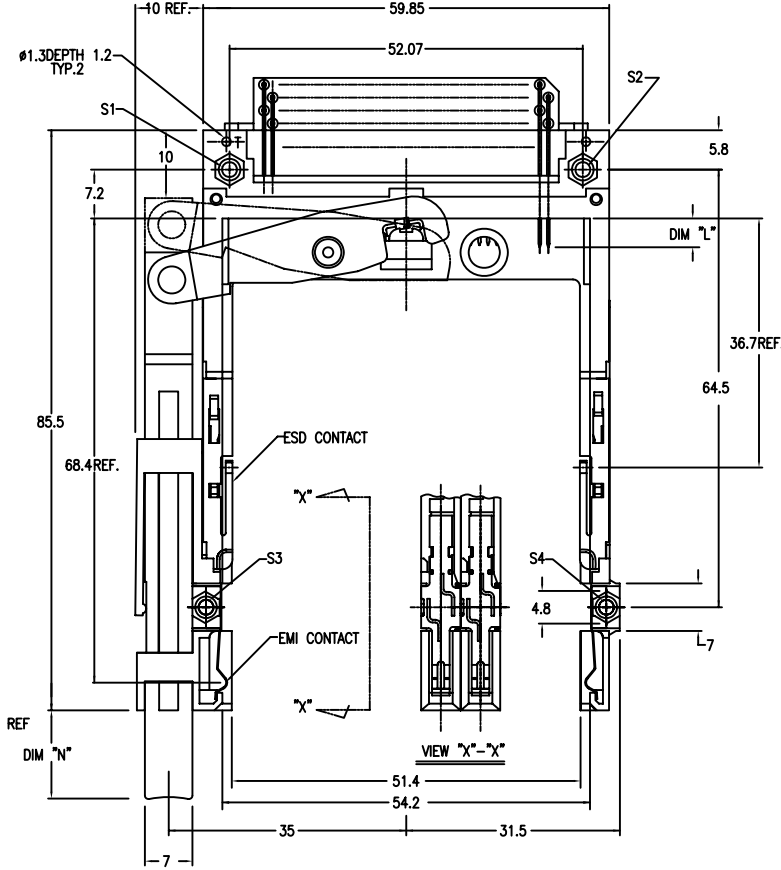
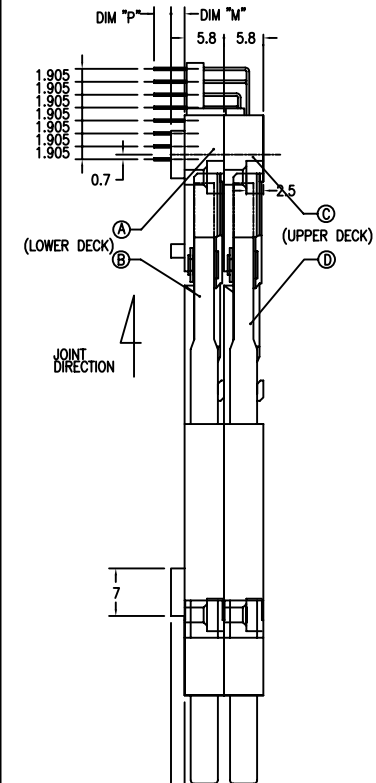

- NOTE
- EJECT FORCE 3.5kg MAX.
 - ASSY PROCESS
 - TO MOUNT PART ④, ⑤ ON PWB WITH SCREW (S1,S2) AND SOLDER.
 - TO JOINT PART ③, ⑥ INTO PART ② THEN FIX PART ③, ⑥ WITH 2 SCREWS (S3,S4).
 - EJECT TRAVEL 8.0mm
 - MATERIAL
 - PART ②, ③ (HEADER ASSY)
 - PLASTIC : HIGH TEMPERATURE THERMOPLASTIC UL94V-0 BLACK
 - PIN : COPPER ALLOY
 - PART ④, ⑤ (EJECT MECHANISM ASSY)
 - PLASTIC : HIGH TEMPERATURE THERMOPLASTIC UL94V-0 BLACK
 - PLATE : STAINLESS
 - EMI CONTACT : COPPER ALLOY
- ⑤ -1 FINISH (PIN)
 UNDER PLATING : 0.5 μm MIN. Ni
 CONTACT AREA : 0.076 μm MIN. GOLD
 SOLDER TAIL : 2.5 μm MIN. Sn-Pb.
- ⑤ -2 FINISH (PIN) (FOR -****LF)
 UNDER PLATING : 0.5 μm MIN. Ni
 CONTACT AREA : 0.076 μm MIN. GOLD
 SOLDER TAIL : 2.5 μm MIN. Sn.
6.

DIM "L"	4.25±0.1	3.5±0.1	5.0±0.1
PIN NUMBER	OTHERS	36.67	36.33
7. GENERAL TOLERANCE : ±0.3
 8. SEE SHEET 1 REGARDING COMPONENTS

mat'l. code		surface		tolerance		projection		product family	
		ISO1302		ISO1302 ISO1101		MM		PCMCIA	
ltr		ecn no		dr		date		title	
K								68P DOUBLE EJECTOR HEADER ASSY FOR TYPE I/II/III	
								dwg no	
								sheet. 5 of 9	
								size	
								A4	
								type	
								Product Customer Drawing	
sheet		revision							
index		sheet							

PART NO.	
92194-500CA	92194-500CALF
92194-500FA	92194-500FALF
92194-520CA	92194-520CALF

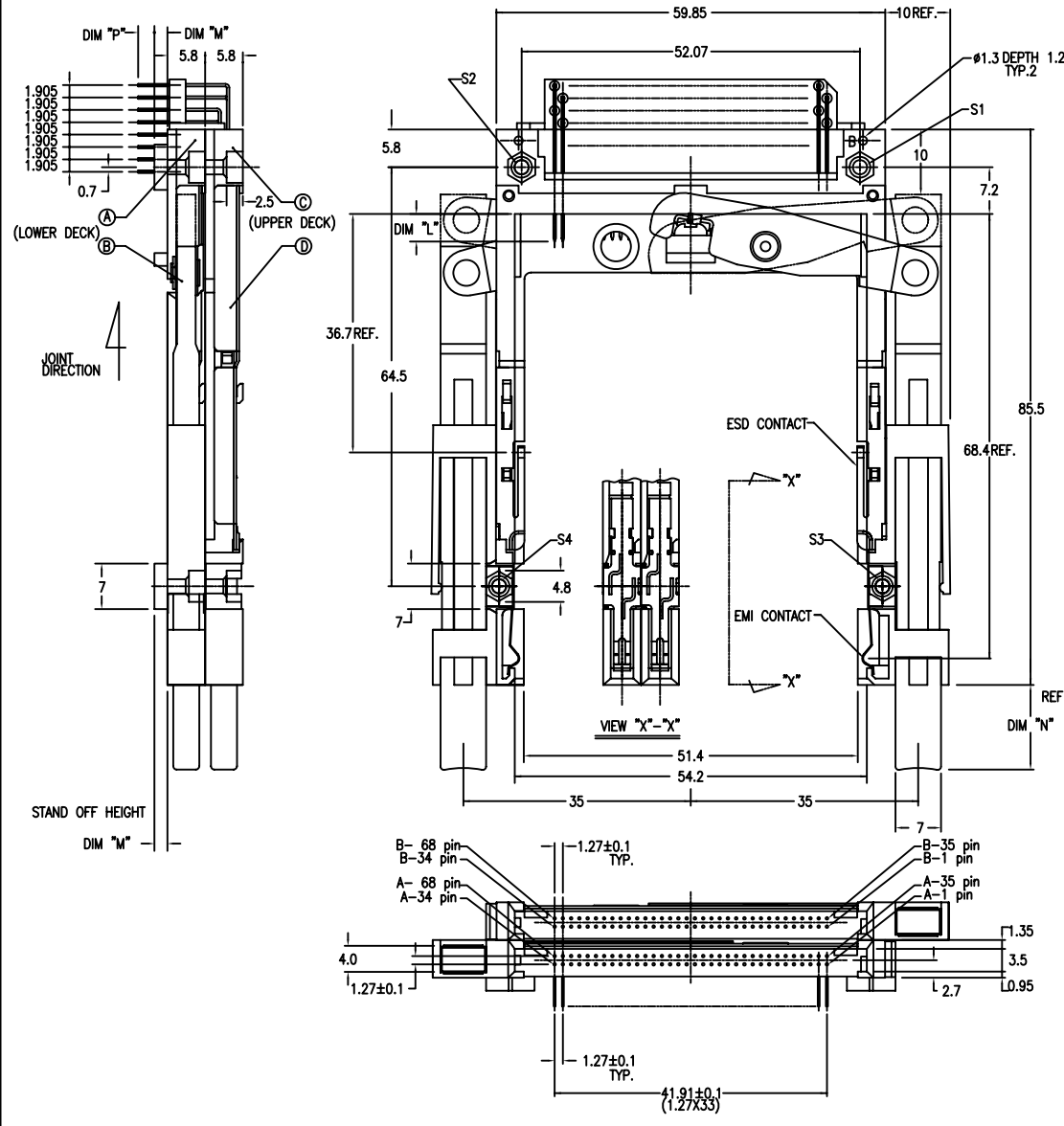

NOTE

1. EJECT FORCE 3.5kg MAX.
2. ASSY PROCESS
 - 2.1 TO MOUNT PART ③, ④ ON PWB WITH SCREW (S1,S2) AND SOLDER.
 - 2.2 TO JOINT PART ③, ④ INTO PART ① THEN FIX PART ③, ④ WITH 2 SCREWS (S3,S4).
3. EJECT TRAVEL 8.0mm

④ MATERIAL

4.1 PART ①, ② (HEADER ASSY)
 PLASTIC : HIGH TEMPERATURE THERMOPLASTIC UL94V-0 BLACK
 PIN : COPPER ALLOY

4.2 PART ③, ④ (EJECT MECHANISM ASSY)
 PLASTIC : HIGH TEMPERATURE THERMOPLASTIC UL94V-0 BLACK
 PLATE : STAINLESS
 EMI CONTACT : COPPER ALLOY

⑤ -1 FINISH (PIN)

UNDER PLATING : 0.5 μ m MIN. Ni
 CONTACT AREA : 0.076 μ m MIN. GOLD
 SOLDER TAIL : 2.5 μ m MIN. Sn-Pb.

⑤ -2 FINISH (PIN) (FOR -*****LF)

UNDER PLATING : 0.5 μ m MIN. Ni
 CONTACT AREA : 0.076 μ m MIN. GOLD
 SOLDER TAIL : 2.5 μ m MIN. Sn.

6.	DIM "L"	4.25±0.1	3.5±0.1	5.0±0.1
	PIN NUMBER	OTHERS	36.67	36.51.68

7. GENERAL TOLERANCE : ±0.3

8. SEE SHEET 1 REGARDING COMPONENTS

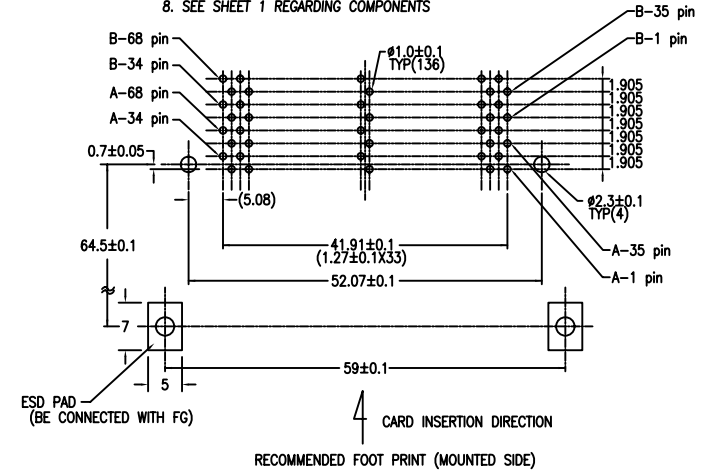

mat'l. code	surface	tolerance	projection	product family			
	ISO1302	ISO1302 ISO1101		PCMCIA			
ltr	ecn no	dr	date	title			
K				68P DOUBLE EJECTOR HEADER ASSY FOR TYPE I/II/III			
				scale 2:1			
	dr	M.HASEGAWO	06/17/05				
	enrg	M.HASEGAWO	06/17/05				
	chr	M.HASEGAWO	06/20/05				
	appd	M.HASEGAWO	06/20/05				
sheet index	revision sheet			dwg no	sheet. 6 of 9	size	
				92194	A4		
				type	Product Customer Drawing		

PART NO.	
92194-600CA	92194-600CALF
92194-620CA	92194-620CALF

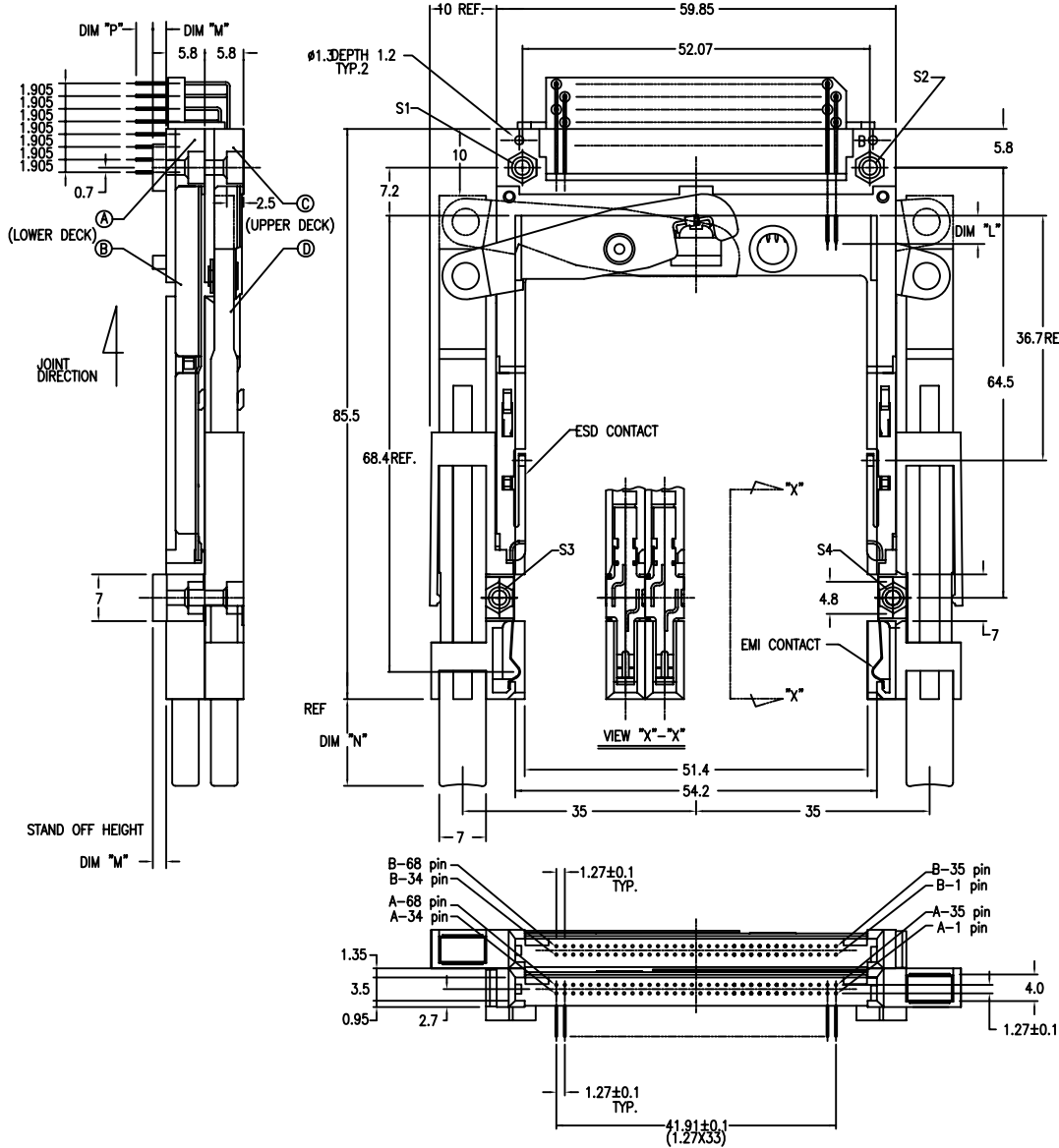

NOTE

- EJECT FORCE 3.5kg MAX.
- ASSY PROCESS
 - TO MOUNT PART (A), (C) ON PWB WITH SCREW (S1,S2) AND SOLDER.
 - TO JOINT PART (B), (D) INTO PART (A), (C) THEN FIX PART (B), (D) WITH 2 SCREWS (S3,S4).
- EJECT TRAVEL 8.0mm

④ MATERIAL

4.1 PART (A), (C) (HEADER ASSY)
 PLASTIC : HIGH TEMPERATURE THERMOPLASTIC UL94V-0 BLACK
 PIN : COPPER ALLOY

4.2 PART (B), (D) (EJECT MECHANISM ASSY)
 PLASTIC : HIGH TEMPERATURE THERMOPLASTIC UL94V-0 BLACK
 PLATE : STAINLESS
 EMI CONTACT : COPPER ALLOY

⑤ -1 FINISH (PIN)

UNDER PLATING : 0.5 μm MIN. Ni
 CONTACT AREA : 0.076 μm MIN. GOLD
 SOLDER TAIL : 2.5 μm MIN. Sn-Pb.

⑤ -2 FINISH (PIN) (FOR -****LF)

UNDER PLATING : 0.5 μm MIN. Ni
 CONTACT AREA : 0.076 μm MIN. GOLD
 SOLDER TAIL : 2.5 μm MIN. Sn.

DIM "L"	4.25±0.1	3.5±0.1	5.0±0.1
PIN NUMBER	OTHERS	36.67	1734 35168

7. GENERAL TOLERANCE : ±0.3

8. SEE SHEET 1 REGARDING COMPONENTS

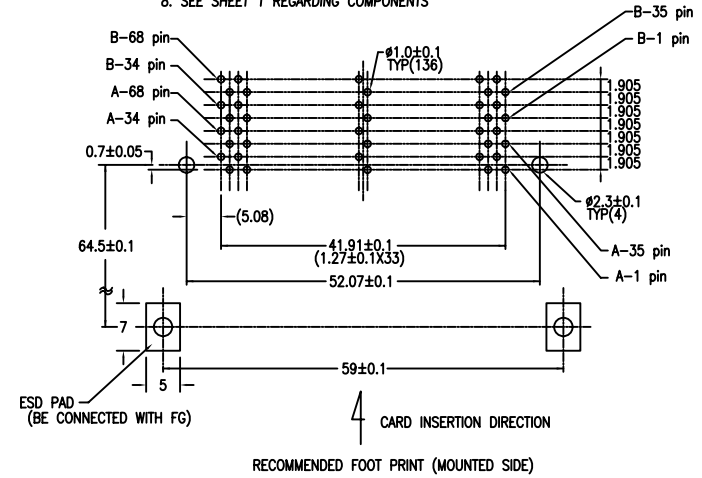

mat'l. code	surface	tolerance	projection	product family
	ISO1302	ISO1302 ISO1101		PCMCIA
ltr	ecn no	dr	date	title
K				68P DOUBLE EJECTOR HEADER ASSY FOR TYPE I/II/III
				dwg no
				92194
				sheet. 7 of 9
				size
				A4
				type
				Product Customer Drawing
sheet	revision			
index	sheet			

PART NO.	
92194-700CA	92194-700CALF
92194-720CA	92194-720CALF

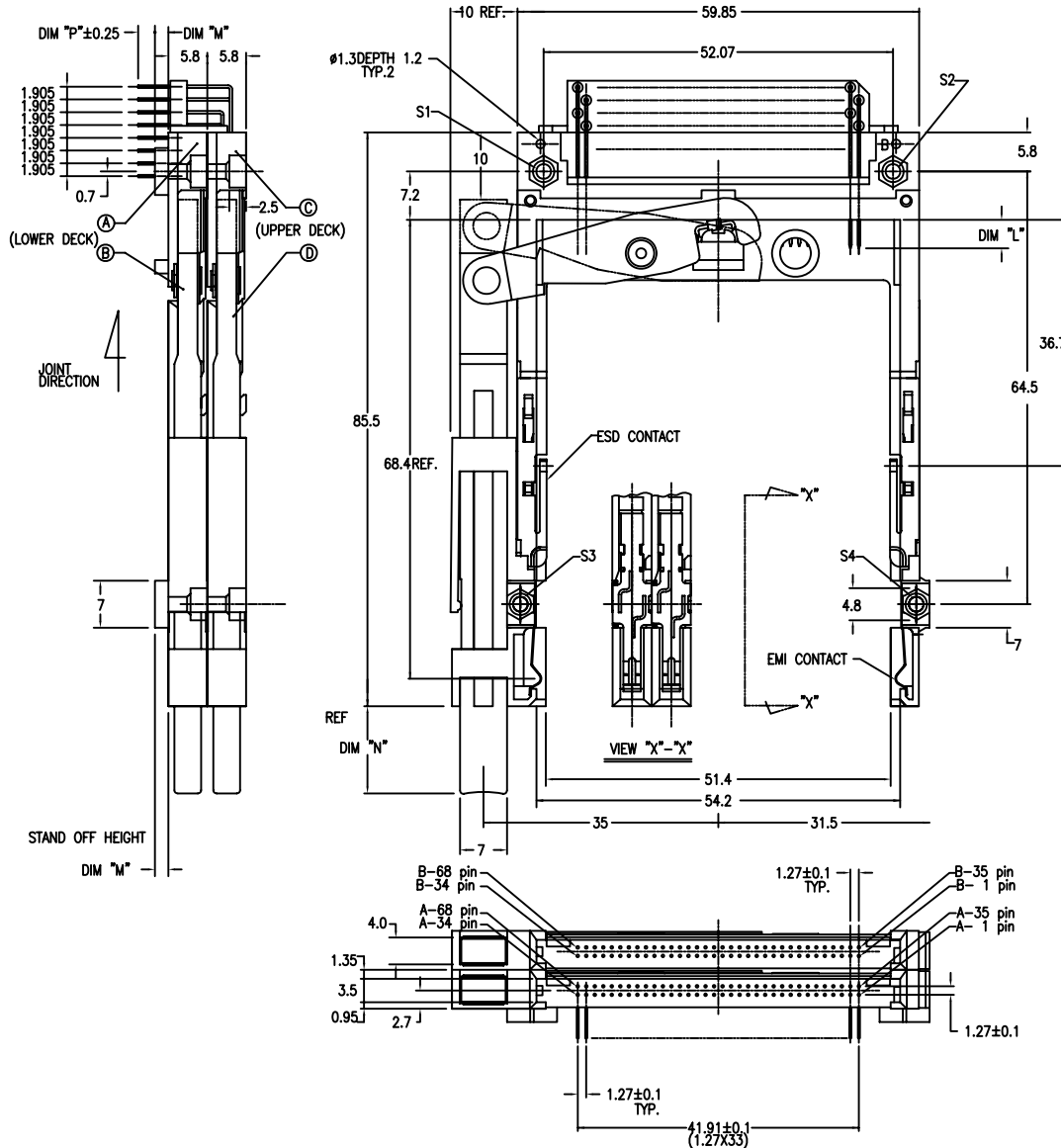

NOTE

- EJECT FORCE 3.5kg MAX.
- ASSY PROCESS
 - TO MOUNT PART ④, ⑤ ON PWB WITH SCREW (S1,S2) AND SOLDER.
 - TO JOINT PART ③, ⑥ INTO PART ④ THEN FIX PART ④, ⑤ WITH 2 SCREWS (S3,S4).
- EJECT TRAVEL 8.0mm

④ MATERIAL

4.1 PART ④, ⑤ (HEADER ASSY)
 PLASTIC : HIGH TEMPERATURE THERMOPLASTIC UL94V-0 BLACK
 PIN : COPPER ALLOY

4.2 PART ③, ⑥ (EJECT MECHANISM ASSY)
 PLASTIC : HIGH TEMPERATURE THERMOPLASTIC UL94V-0 BLACK
 PLATE : STAINLESS
 EMI CONTACT : COPPER ALLOY

⑤ -1 FINISH (PIN)

UNDER PLATING : 0.5 μm MIN. Ni
 CONTACT AREA : 0.076 μm MIN. GOLD
 SOLDER TAIL : 2.5 μm MIN. Sn-Pb.

⑤ -2 FINISH (PIN) (FOR -****LF)

UNDER PLATING : 0.5 μm MIN. Ni
 CONTACT AREA : 0.076 μm MIN. GOLD
 SOLDER TAIL : 2.5 μm MIN. Sn.

DIM "L"	4.25±0.1	3.5±0.1	5.0±0.1
PIN NUMBER	OTHERS	36,67	36,68

6. GENERAL TOLERANCE : ±0.3

8. SEE SHEET 1 REGARDING COMPONENTS

REF.

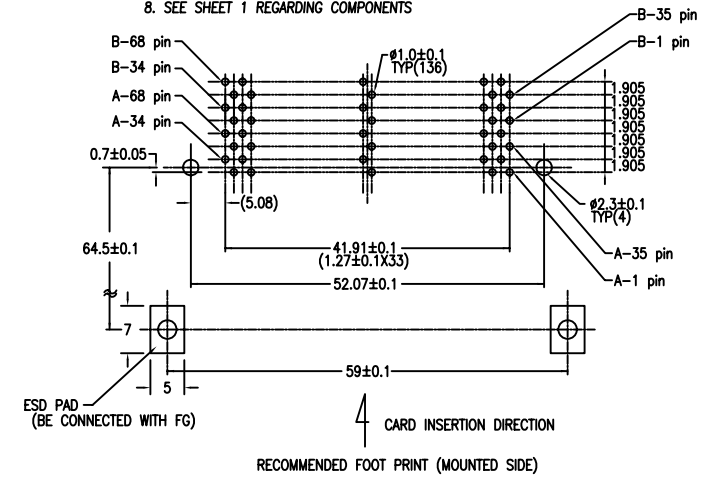

mat'l. code	surface	tolerance	projection	product family
	ISO1302	ISO1302 ISO1101		PCMCIA
ltr	ecn no	dr	date	title
K				68P DOUBLE EJECTOR HEADER ASSY FOR TYPE I/II/III
				dwg no
				92194
				sheet. 8 of 9
				size
				A4
				type
				Product Customer Drawing
sheet	revision			
index	sheet			

PART NO.	
92194-800CA	92194-800CALF
92194-820CA	92194-820CALF

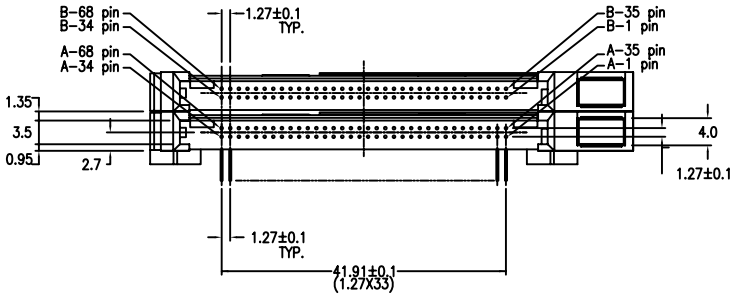
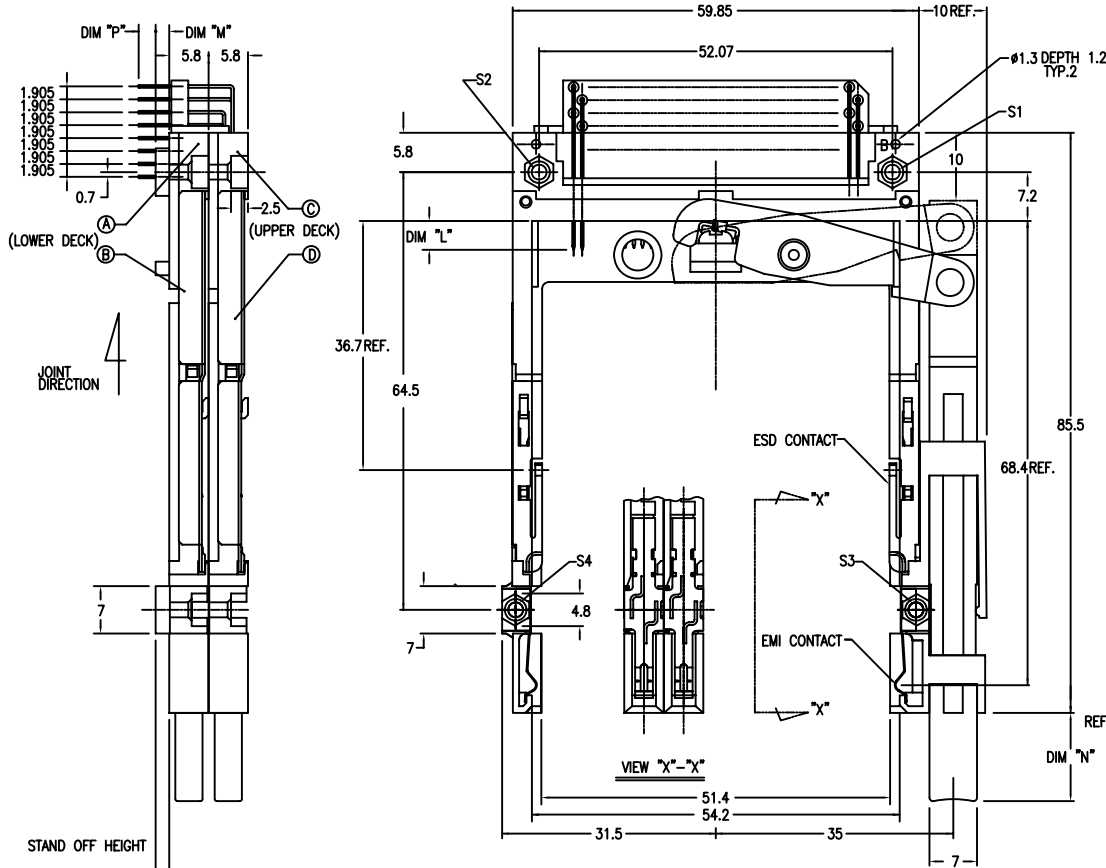

NOTE

- EJECT FORCE 3.5kg MAX.
- ASSY PROCESS
2.1 TO MOUNT PART ④, ⑤ ON PWB WITH SCREW (S1,S2) AND SOLDER.
2.2 TO JOINT PART ⑥, ⑦ INTO PART ④ THEN FIX PART ⑥, ⑦ WITH 2 SCREWS (S3,S4).
- EJECT TRAVEL 8.0mm

④ MATERIAL
4.1 PART ④, ⑤ (HEADER ASSY)
PLASTIC : HIGH TEMPERATURE THERMOPLASTIC UL94V-0 BLACK
PIN : COPPER ALLOY

4.2 PART ⑥, ⑦ (EJECT MECHANISM ASSY)
PLASTIC : HIGH TEMPERATURE THERMOPLASTIC UL94V-0 BLACK
PLATE : STAINLESS
EMI CONTACT : COPPER ALLOY

- ⑤ -1 FINISH (PIN)
UNDER PLATING : 0.5 μ m MIN. Ni
CONTACT AREA : 0.076 μ m MIN. GOLD
SOLDER TAIL : 2.5 μ m MIN. Sn-Pb
- ⑤ -2 FINISH (PIN) (FOR -****LF)
UNDER PLATING : 0.5 μ m MIN. Ni
CONTACT AREA : 0.076 μ m MIN. GOLD
SOLDER TAIL : 2.5 μ m MIN. Sn.

6.	DIM "L"	4.25±0.1	3.5±0.1	5.0±0.1
	PIN NUMBER OTHERS	36.67	117.34	351.68

- GENERAL TOLERANCE : ±0.3
- SEE SHEET 1 REGARDING COMPONENTS

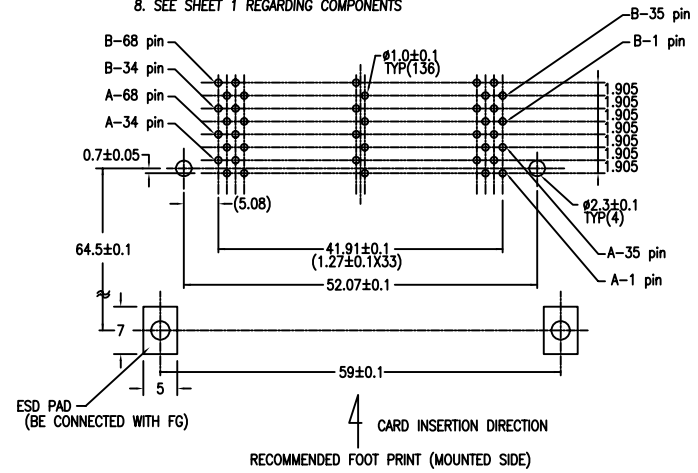

mat'l. code		surface		tolerance		projection		product family	
		ISO1302		ISO1302 ISO1101		MM		PCMCIA	
ltr		ecn no		dr		date		title	
K								68P DOUBLE EJECTOR HEADER ASSY FOR TYPE I/II/III	
								dwg no	
								sheet. 9 of 9	
								size	
								A4	
								type	
								Product Customer Drawing	
sheet index		revision sheet							